

# Specifications

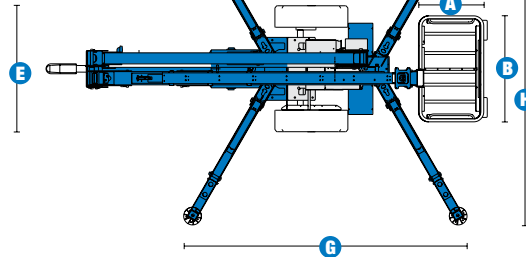
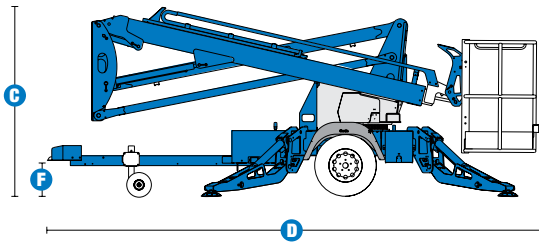

**MODEL** TZ™-34/20

MEASUREMENTS	Metric	US
Working height*	12.36 m	40 ft
Platform height	10.36 m	34 ft
Entry height - extended	0.16 m	6.4 in
Horizontal reach	5.59 m	18 ft 4 in
Clear out reach	4.09 m	13 ft 5 in
Up and over clearance	4.90 m	16 ft 1 in
<b>A</b> Platform length	0.68 m	2 ft 2.8 in
<b>B</b> Platform width	1.12 m	3 ft 8 in
<b>C</b> Height - stowed	1.94 m	6 ft 4.5 in
<b>D</b> Length - stowed	5.50 m	18 ft 0.5 in
<b>E</b> Width - stowed	1.45 m	4 ft 9.1 in
<b>F</b> Ground clearance	0.24 m	9.5 in
<b>G</b> Length - outrigger footprint	3.26 m	10 ft 8.4 in
<b>H</b> Width - outrigger footprint	3.59 m	11 ft 9.4 in

**PRODUCTIVITY**

Lift capacity - standard	200 kg	440 lbs
Lift capacity - rotating platform	181 kg	400 lbs
Self leveling platform	standard	
Platform rotation option	90° mechanical	
AC power to platform	standard	
Turntable rotation	359° non-continuous	
Outrigger leveling capability	11°	11°
Towing speed rate	97 km/h	60 mph
Tongue weight	74 kg	163 lbs
Surge and parking brakes	standard	
Controls	variable speed system	
Tyre size	ST 205/75 R15	
Coupler	5.08 cm (2 in) hitch coupler standard	

**POWER**

Power source	24 V DC (four 6V 225 Ah batteries)	
Hydraulic tank capacity	14.57 L	3.85 gal
Hydraulic system capacity	17 L	4.5 gal

**WEIGHT\*\***

	1,450 kg	3,197 lbs
--	----------	-----------

**STANDARDS COMPLIANCE** ANSI A92.2, CSA C225, CE Compliance, AS 1418.10

**RANGE OF MOTION TZ™-34/20**

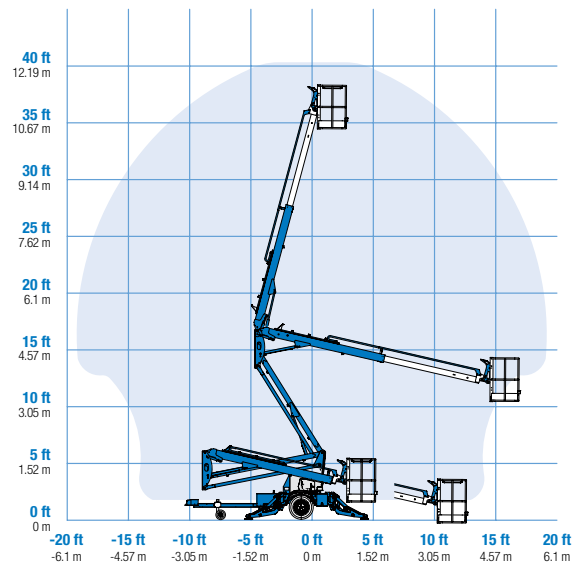

\* The metric equivalent of working height adds 2 m to platform height. U.S. adds 6 ft to platform height.  
 \*\* Weight will vary depending on options and/or country standards.

## Features

### STANDARD FEATURES

#### MEASUREMENTS

- 12.36 m (40 ft) working height
- 5.59 m (18 ft 4 in) horizontal reach
- Up to 200 kg (440 lbs) lift capacity

#### PRODUCTIVITY

- 0.68 m x 1.12 m (2 ft 3 in x 3 ft 8 in) aluminium platform
- ST 205/75 R15 tyres
- Industry leading working envelope
- Extension boom
- Self-leveling platform
- Variable speed control system
- Hydraulic outriggers
- Automatic 11° leveling system
- Outrigger interlocks
- Mechanical parking brake
- Hydraulic surge brakes
- Auxiliary pump down
- 5.08 cm (2 in) coupler lever lock
- Hitch pull bar
- Dual jockey wheels
- 359° non-continuous turntable rotation
- Easy to access batteries
- Hour meter
- Tilt alarm sensor with audible alarm
- Forklift pockets
- Illuminated outrigger indicators
- Full size spare tyre
- Operational warning beacon package
- Non-marking outrigger footpads

#### POWER

- 24 V DC power source
- Universal 20 amp smart charger

### OPTIONS & ACCESSORIES

#### PRODUCTIVITY

- 90° mechanical platform rotation
- Combination hitch
- Fluorescent tube caddy
- Battery charge indicator (BCI)
- Tool tray

#### POWER OPTIONS

- 240 V power to platform

